



Improve Your Winter Ventilation!

Control the Wind™ with the VAL-CO® Hemisphere® Mixing Fan

Note: Protective cage removed to show product.

- Patent Pending Technology.
- Two sizes, 48" and 72" diameters, cover a wide range of applications.
- Ideal for **layer pullet, layer, and floor bird** applications.
- VAL-CO's innovative design dramatically reduces temperature variations in the facility by moving a large volume of air with minimal drafts.
 - Growers report **down to 2** degrees of temperature difference throughout layer and pullet houses.
 - Growers report **more than 10%** improvement in manure belt moisture removal.
 - Growers report **more than 1/2 LB/100** improved feed conversion.
- Large diameter rotors (48" & 72") and slower rotation promotes quiet operation that does not disturb birds.
- **Controls circulation** through the entire building volume with minimal dead spots, improving heat distribution considerably.
- Optional **dampened** air inlet introduces air from attic or outside.
 - Controls fresh air inlet volume.
 - Provides a method to mix the warmest air in the house with fresh outside air before contacting the birds; significantly reducing drafts and cold zones during minimum ventilation.
 - Can eliminate the need for other inlets during initial stages of minimum ventilation.
 - **House winter air exchange required determined by moisture and CO2 requirements.**
- Exhaust fan efficiency improves and electrical load reduced due to very low static pressure operation.
- Robust design and materials ensure years of trouble free operation.
- Precision machined hub keeps rotor turning true.
- Optional VFD controls for variable speed operation available. (Ideal for pullets.)
- System can be interfaced with existing whole house controls.

This diagram shows the airflow pattern of this patent pending technology.

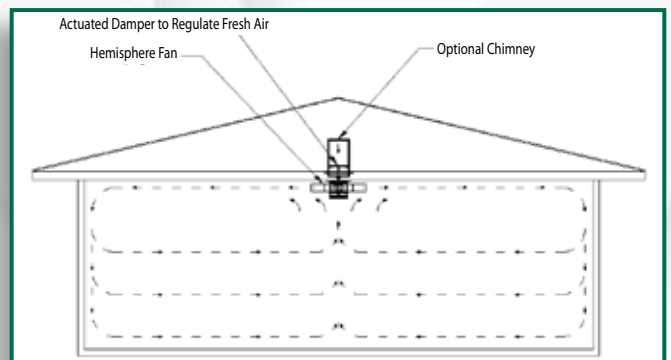

Chimney Kit and VFD Controls



VFD Controls for variable speed operation

Item Number	Description
Chimney	
972037	24" Chimney Kit, F/ Attic
972166	24" Chimney Kit, W/ Dome & Bird Netting
972101	36" Chimney Kit, F/ Attic
972167	36" Chimney Kit, W/ Dome & Bird Netting
VFDs	
921185	2HP VFD Panel; 200-230V, 1PH/3PH, 50/60Hz
921184	5HP VFD Panel; 230V, 1PH/3PH, 60Hz
921186	10HP VFD Panel; 230V, 3PH, 60Hz
921187	10HP VFD Panel; 380-480V, 3PH, 60Hz

Hemisphere Fan Models

Item Number / Description	CFM (est.)	HP	Frequency (Hz)	Phase	Voltage	Weight (lbs.)	VFD Controllable
972140 Hemisphere Fan 48" Std. Capacity, w/ Wire Guard	23,000	1.0	60	1	115/230	300	N
972090 Hemisphere Fan 48" Std. Capacity, w/ Wire Guard	23,000	1.0	60	3	208-230/460	300	Y
972180 Hemisphere Fan 48" High Capacity, w/ Wire Guard	32,000	1.5	60	3	208-230/460	300	Y
972120 Hemisphere Fan 72" Std. Capacity, w/ Wire Guard	38,000	1.5	60	3	208-230/460	400	Y
972160* Hemisphere Fan 72" High Capacity, w/ Wire Guard	45,500	3	60	3	208-230/460	550	Y

* Motor Name Plate: 3HP, Volts 208-230/460, FL Amps 15-14.4/7.2, 3PH

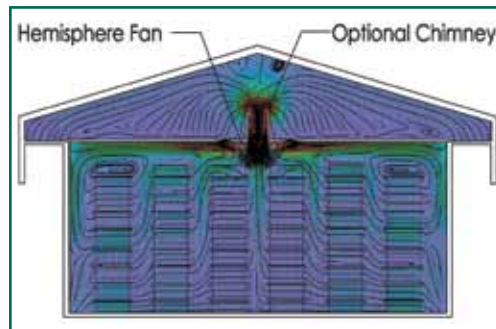

Note: Protective cage removed to show product.

Call your local **VAL-CO** representative or distributor for more information on these and our other fine products.

North America:

Phone: 800-99VALCO (800-998-2526)

Fax: (+1) 419-678-2200

E-mail: sales@val-co.com

International:

Phone: (+1) 419-678-8731

Fax: (+1) 419-678-2200

E-mail: intl.sales@val-co.com



Performance You Can Count On

www.val-co.com